

HD 70 HV

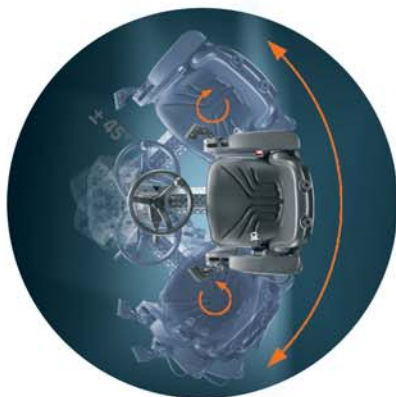

Articulated tandem roller

- ▶ Ergonomic operator's compartment with access from either the left or right side
- ▶ A full 180° rotating operator's station with swiveling seat and tilt steering wheel
- ▶ Excellent visibility to the drum surfaces, drum edges and work areas
- ▶ 3.9" drum offset to either left or right side
- ▶ Hydrostatic dual drum drive, infinitely variable
- ▶ High performance, turbo-charged diesel engine that meets all current EPA emission requirements
- ▶ Dual pump water system with all spray nozzles clearly visible from the operator's seat

TECHNICAL DATA

HD 70 HV

HD 70 HV - Articulated tandem roller

Weights		
Operating weight with ROPS/FOPS	lbs (kg)	15,432(7000)
Maximum weight	lbs (kg)	21,825 (9900)
Axle load, front/rear	lbs (kg)	7,809/7,623 (3542/3458)
Static linear load, front/rear	lbs / in (kg/cm)	132/129 (23,6/23,1)

Machine Dimensions		
Drum width	in (mm)	59 (1500)
Max. working width	in (mm)	63 (1600)
Turning radius, inside	in (mm)	164.3 (4174)

Diesel engine		
Manufacturer	DEUTZ	
Model	TD 2011 L04 W	
Number of cylinders	4	
Power rating DIN/ISO30461FN kW/HP/rpm	63,0/85.7/2500	
Power rating SAE J1349, HP/kW/rpm	84.4/63,0/2500	
Fuel tank, capacity	Gal (Ltr)	37 (140)

Drive		
Hydrostatic drive, front/rear	Hydraulic motor/hydraulic motor	
Speed, work range	mph (km/h)	0-3.9 (0-6,3)
Speed, transport range	mph (km/h)	0-7.8 (0-12,6)
Climbing ability, vibration on/off	%	30/40

Vibration system		
Hydrostatic drive, Double drum vibration		

Vibration		
Vibration frequency, front, low/high	vpm (Hz)	2,880/3,480 (48/58)
Vibration frequency, rear, low/high	vpm (Hz)	2,880/3,480 (48/58)
Amplitude, front, high/low	in (mm)	.024/.014 (0,62/0,35)
Amplitude, rear, high/low	in (mm)	.024/.014 (0,62/0,35)
Centrifugal force, front, high/low	lbs (kN)	17,100/13,950 (76/62)
Centrifugal force, rear, high/low	lbs (kN)	17,100/13,950 (76/62)

Steering		
Steering, type	Pivoted steering	
Steering, actuation	hydrostatic, steering wheel	
Steering angle +/-	Grad	36°
Oscillation angle +/-	Grad	10°

Brake system		
Service brake, mode of action	hydrostatic	
Service brake, actuation	Drive lever	
Parking brake, mode of action	Spring-loaded/multi-disc	
Parking brake, actuation	Electric and/or automatic	
Emergency brake, mode of action	hydr./mech.	
Emergency brake, actuation	Emergency stop button	

Sprinkler system		
Water sprinkler, type	Pressure	
Actuation, sprinkling	interval/manual	
Water tank, capacity	Gal (Ltr)	190 (720)

Standard equipment
Suspended operator's platform, swiveling and rotating operator's seat, 2 multifunctional levers, left and right at seat, indicators for: engine temperature, working hours, fuel level, control lights and emergency stop button, 2 work lights front and rear, main battery switch. Indicators for: hydraulic oil temperature, water level in tanks. CE-conformity.

Optional equipment
Panoramic ROPS cab with: heater, dust-free ventilation, sun shade, interior lighting, front and rear wipers, interior mirror, beacon, lights according to German Road Regulation and seat belt. Radio. Tachometer. Air conditioning. Edge pressing and cutting equipment. Special paint. Asphalt temperature gauge. Night paving light kit.

Further data on request / subject to change

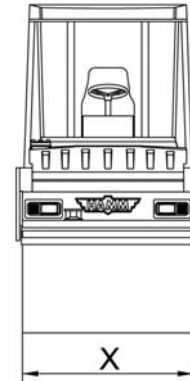
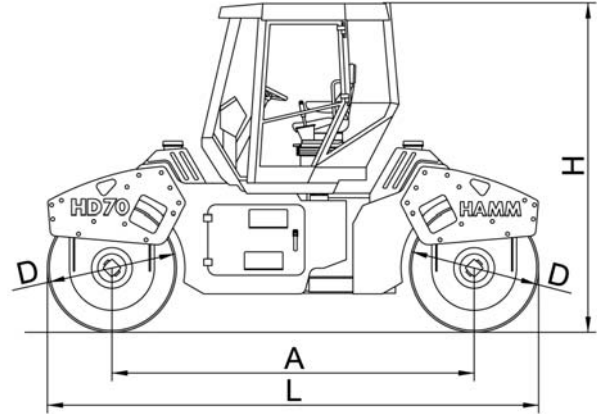

		HD 70 HV
Total length	L	171" (4340)
Total width	B	63.4" (1610)
Total height	H	114.6" (2910)
Wheel base	A	126.0" (3200)
Drum width	X	59" (1500)
Drum diameter	D	45" (1140)